

Vibration Analysis

Basic Concepts

Vibration waveforms

Vibration amplitude

Time Domain

Frequency Domain

Examples of Vibration

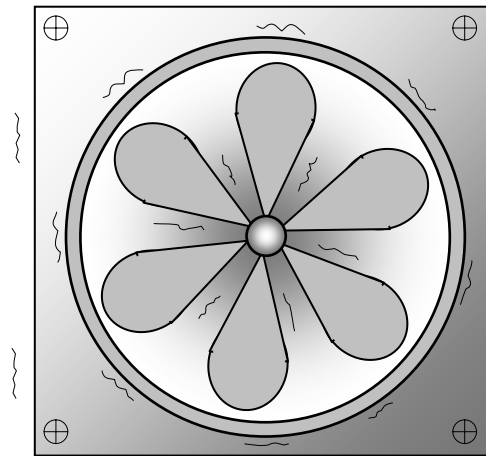
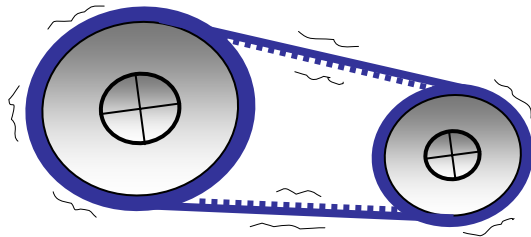
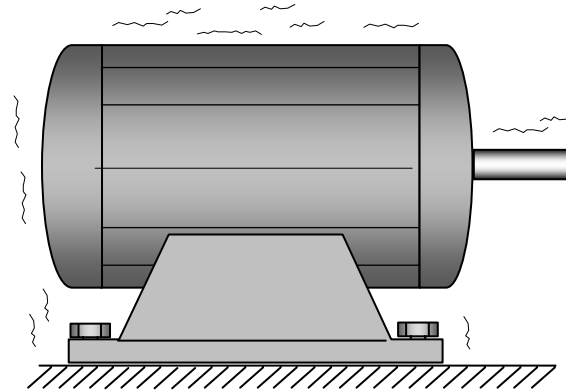
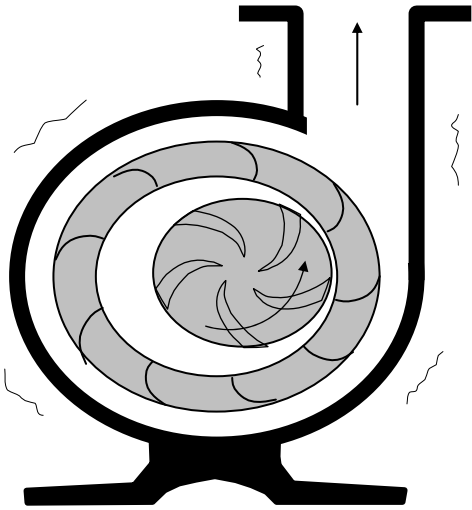

How do we measure vibration?

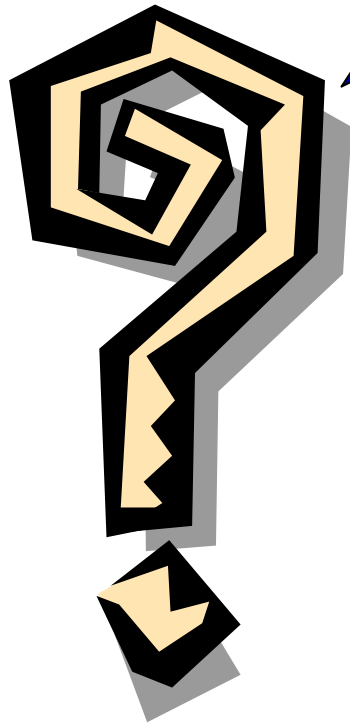

**Choose a
point to
measure**

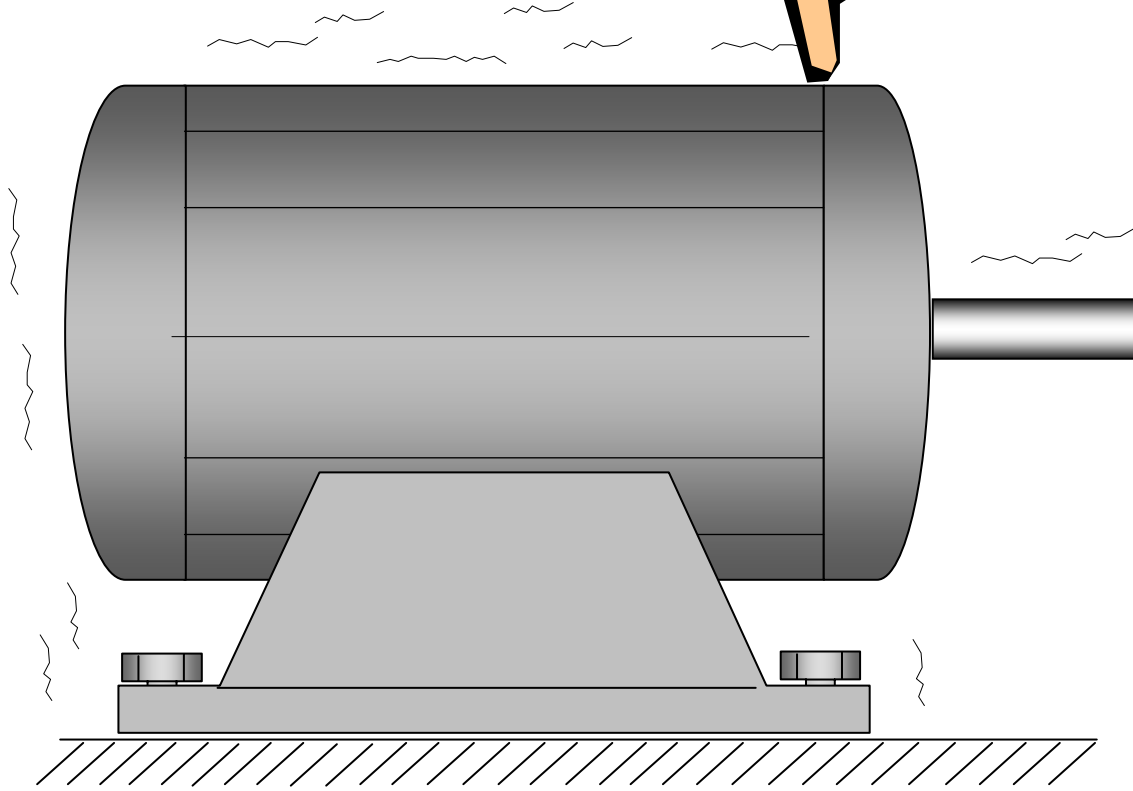
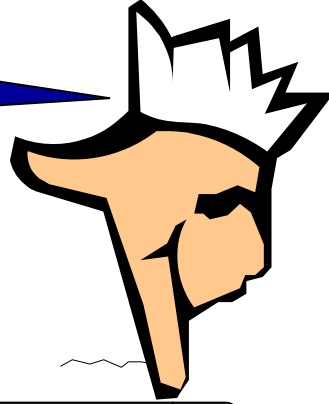

**Choose a
direction**

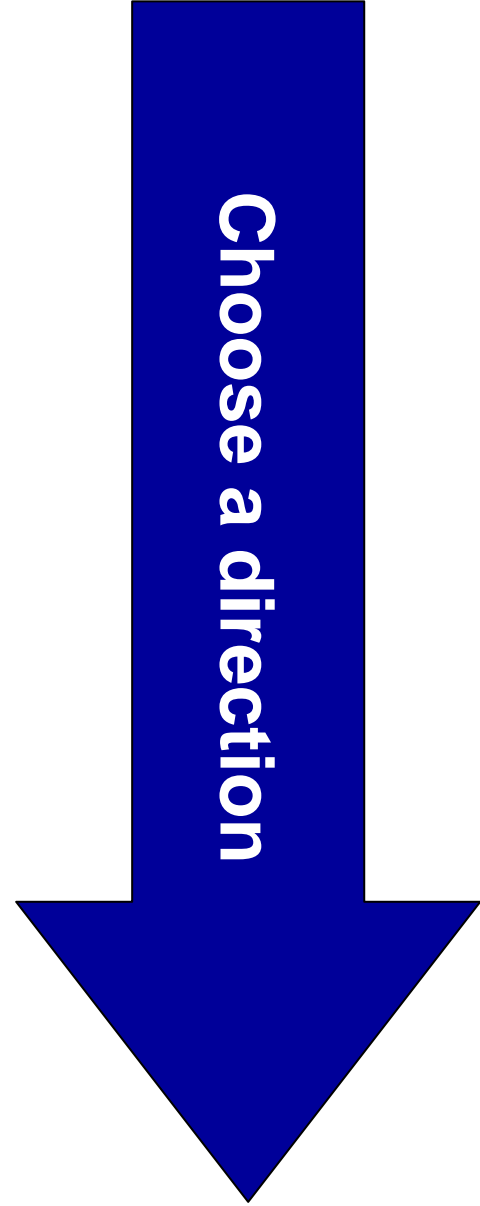

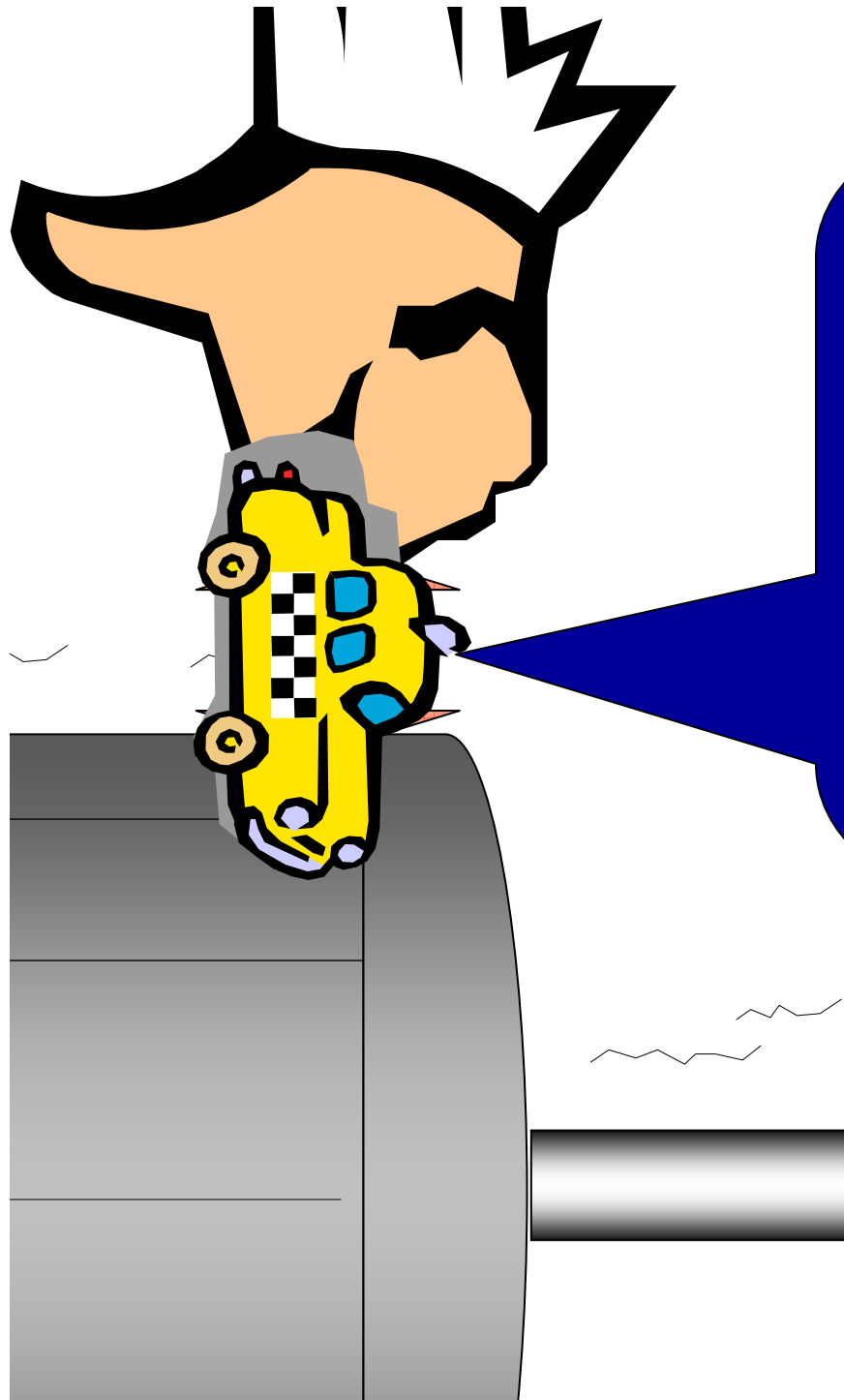

We can measure...

DISPLACEMENT

VELOCITY

or

ACCELERATION

At any point in time...

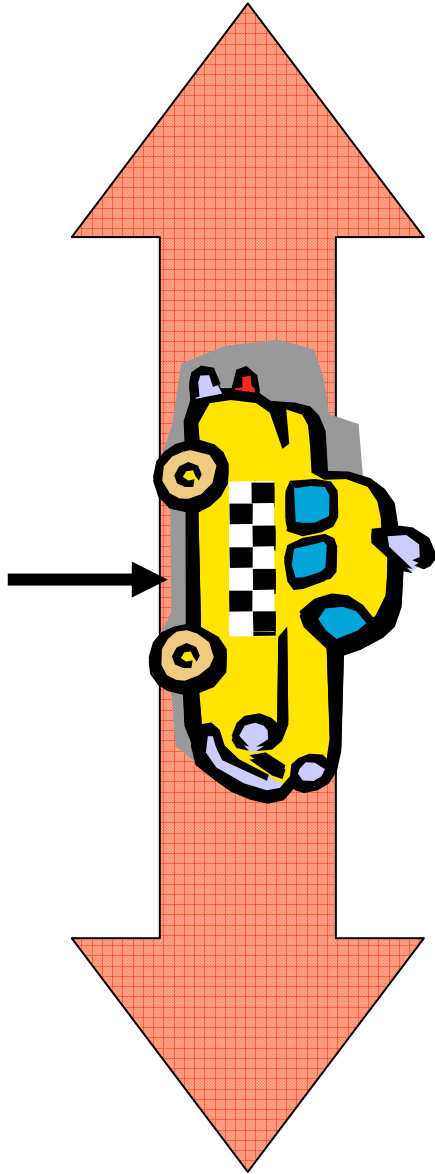

DISPLACEMENT =
Distance traveled (miles)

VELOCITY =
Speedometer reading
(mph)

ACCELERATION =
How far your foot is down.

Displacement

- **Actual physical movement of a vibrating object**
- **Emphasizes lower frequency components**
- **Measured in mils or microns**

Displacement is the easiest to visualize

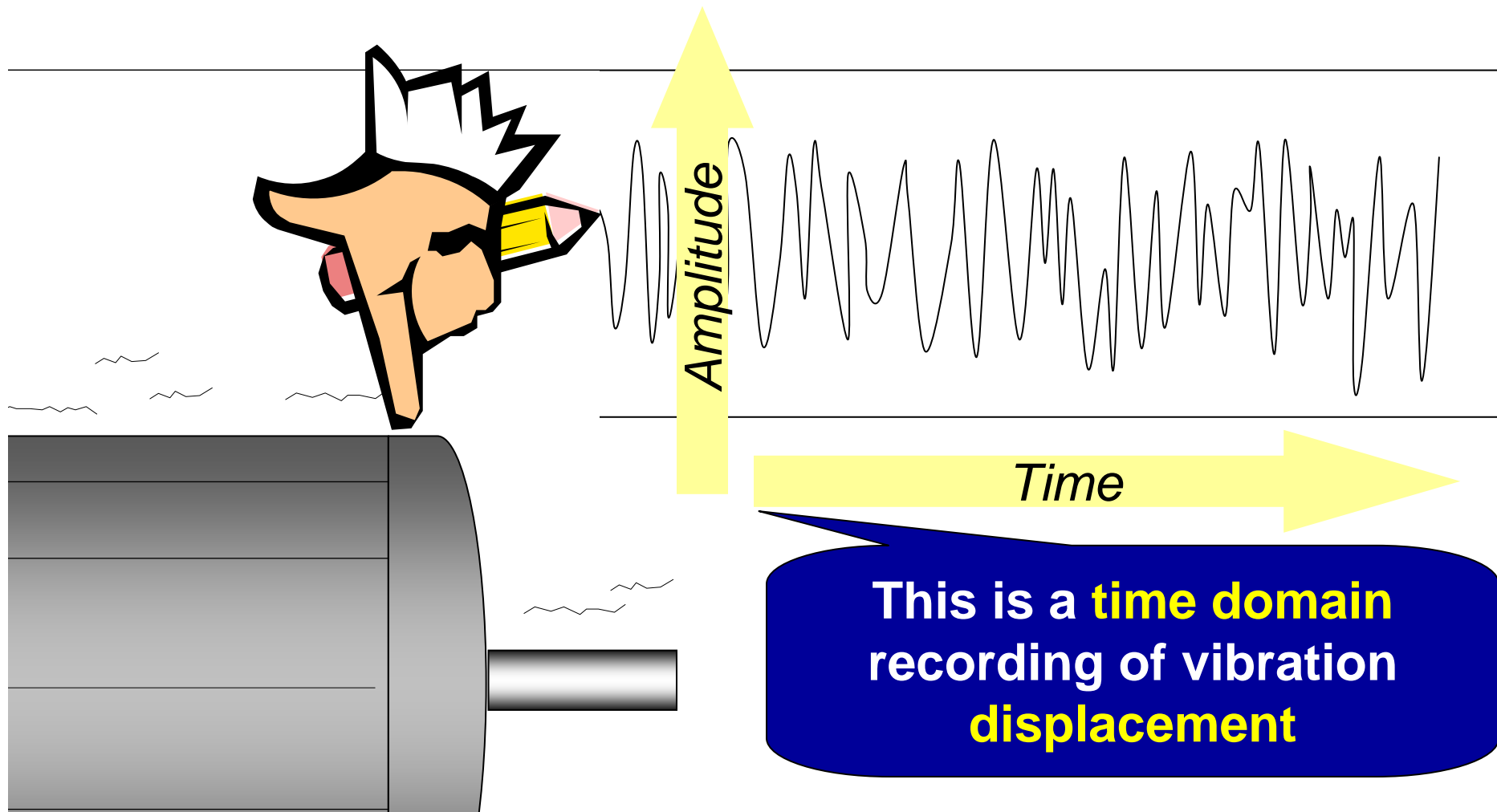

Velocity

- **Measure of the speed at which the mass is moving**
- **Preferred unit of measurement as it effective over over a wide range, from low frequency to high frequency**
- **Measured in inches / sec or mm / sec**

Velocity or speed is zero as the object comes to a stop before moving in the opposite direction

Speed or velocity is greatest here

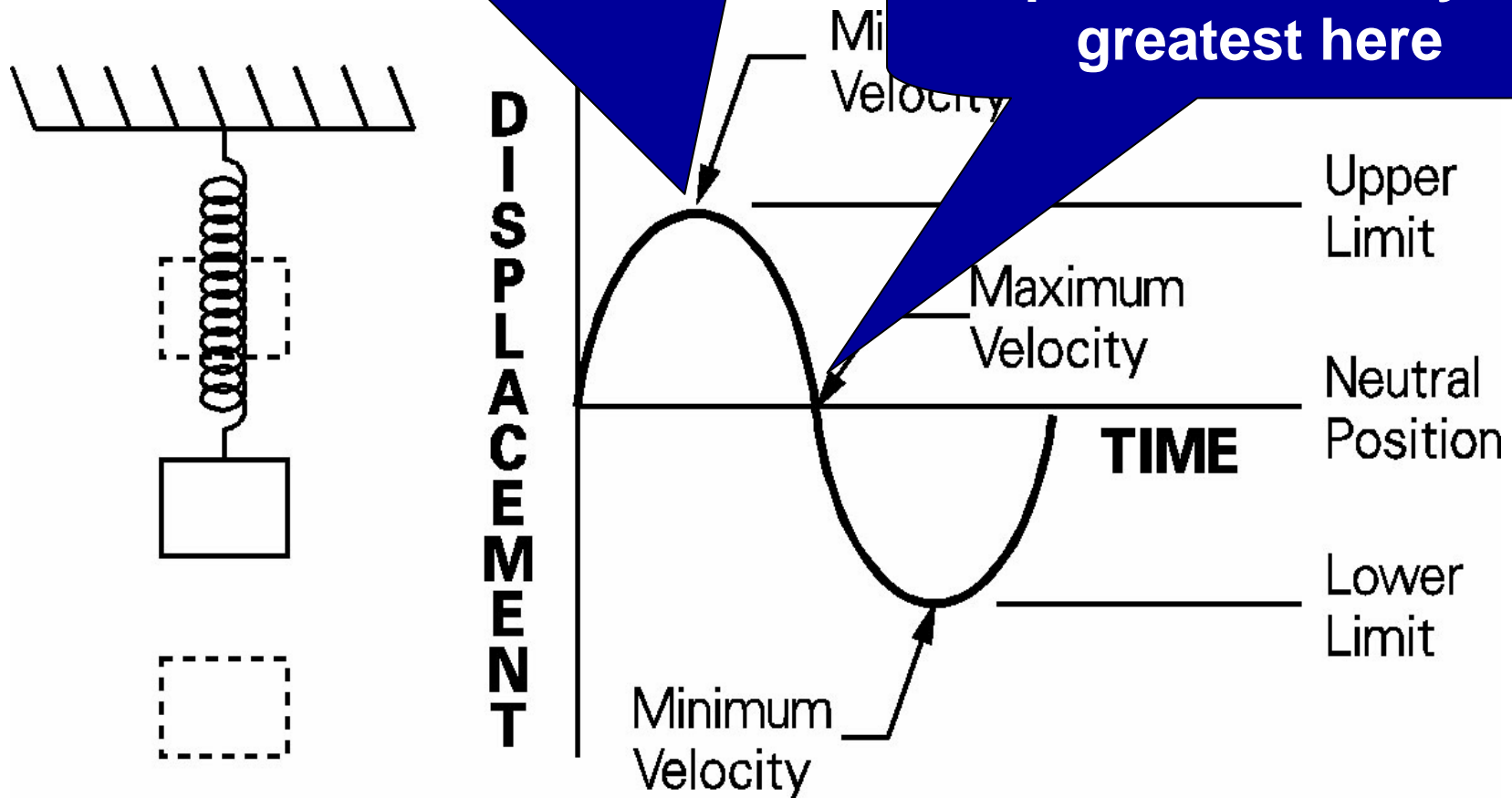

Acceleration

- **Rate of change of Velocity**
- **Emphasizes high-frequency peaks in a spectrum**
- **Measured in “g’s”**

Acceleration is greatest where velocity is at a minimum

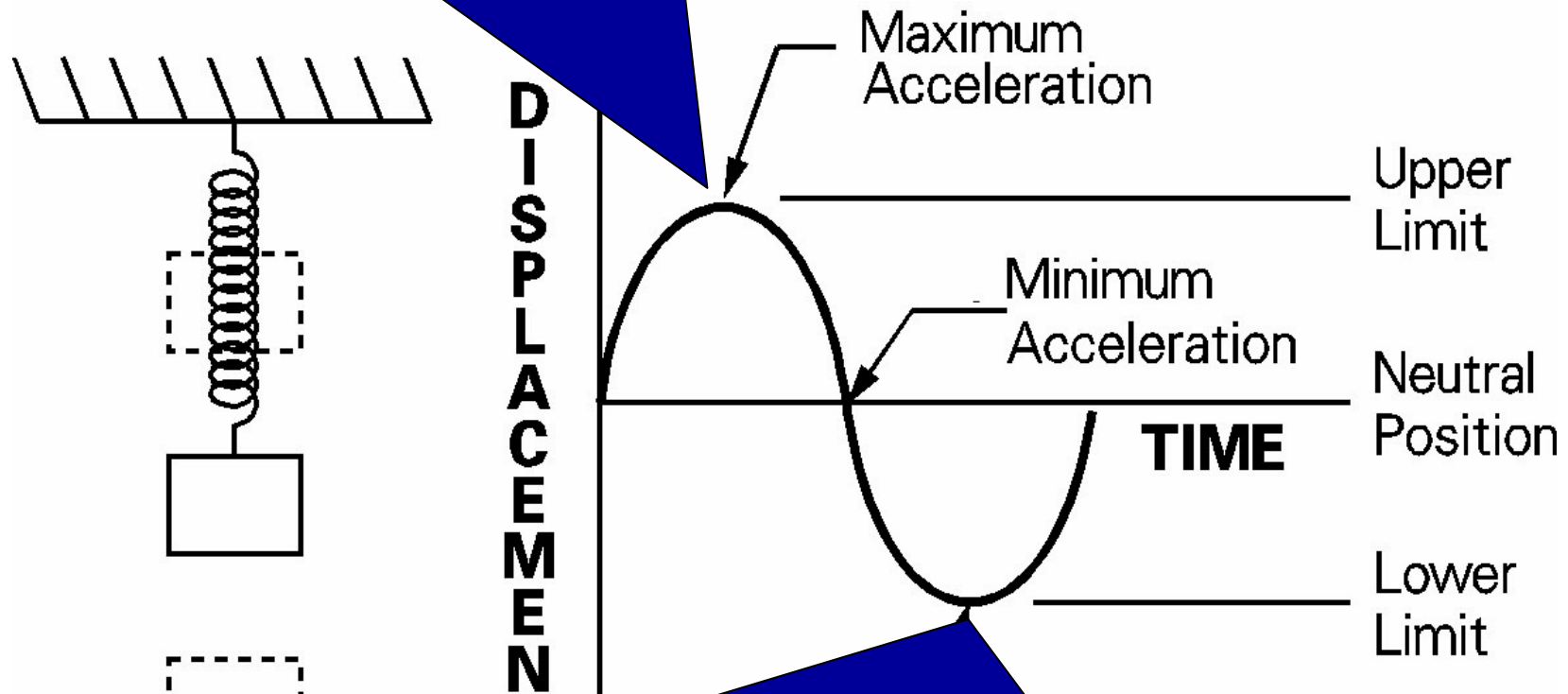

Object has decelerated and stopped and is about to begin accelerating again

Comparison of Velocity, Displacement & Acceleration

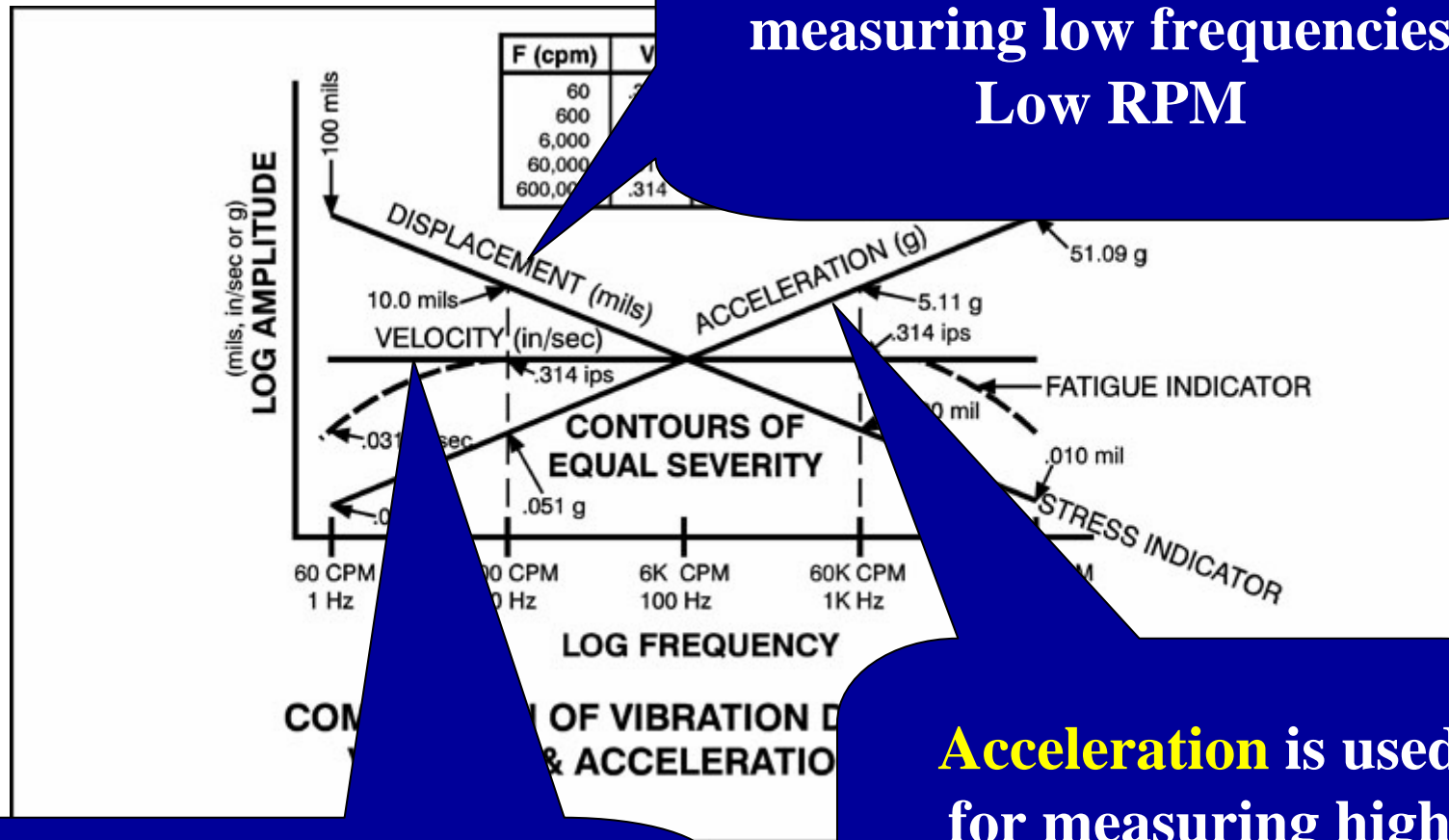

Displacement is used for measuring low frequencies:
Low RPM

Velocity is best over a wide frequency range

Acceleration is used for measuring high frequencies:
Bearing Frequencies

Simple Harmonic Motion

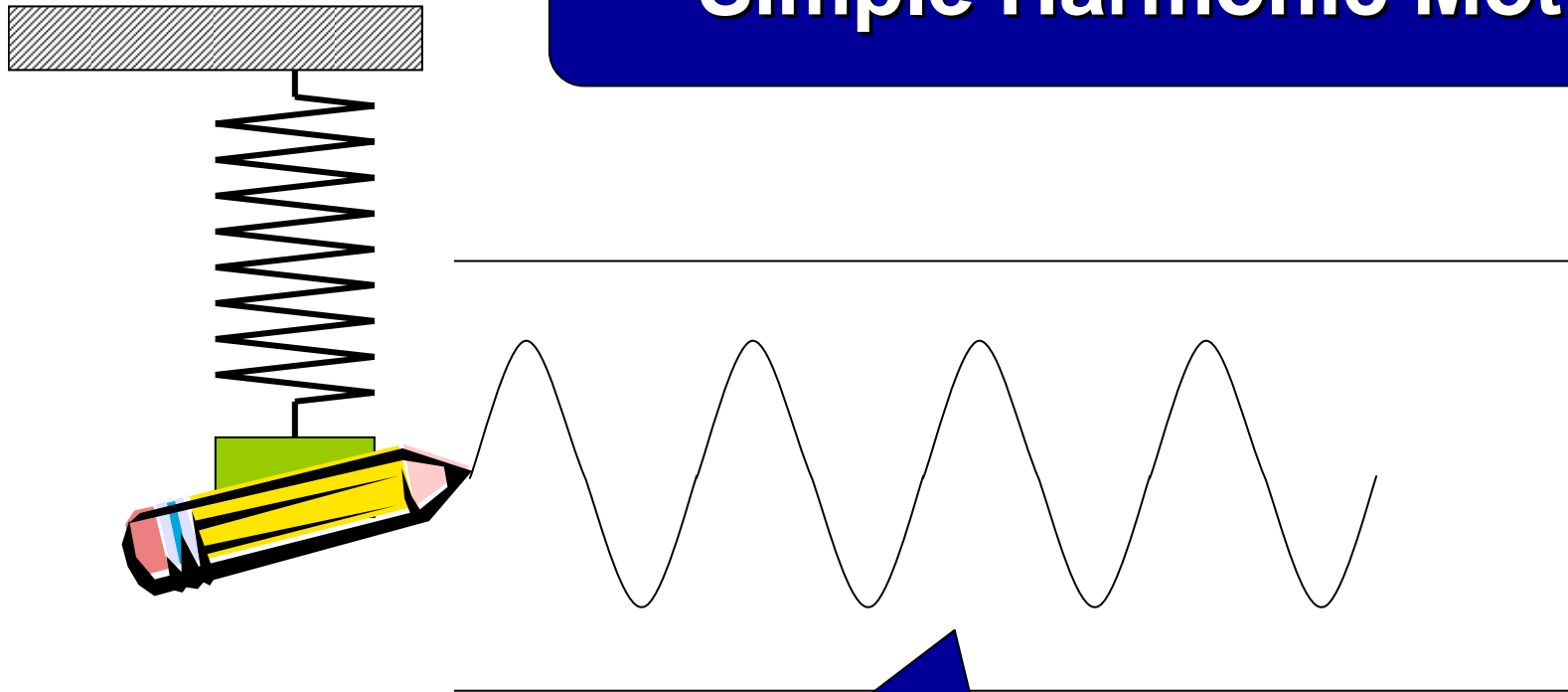

This displacement waveform is **sinusoidal**.

Simple Harmonic Motion - The **Simplest** Vibration

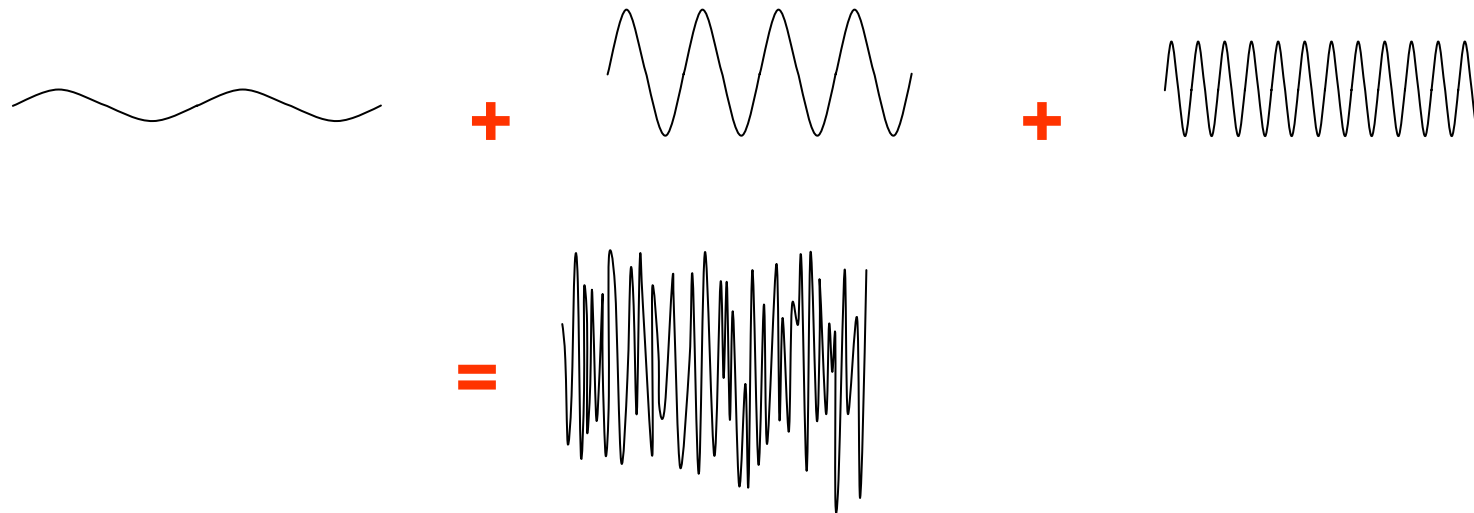

ANY vibration can be expressed as a **sum** of individual simple vibrations.

The Frequency Domain

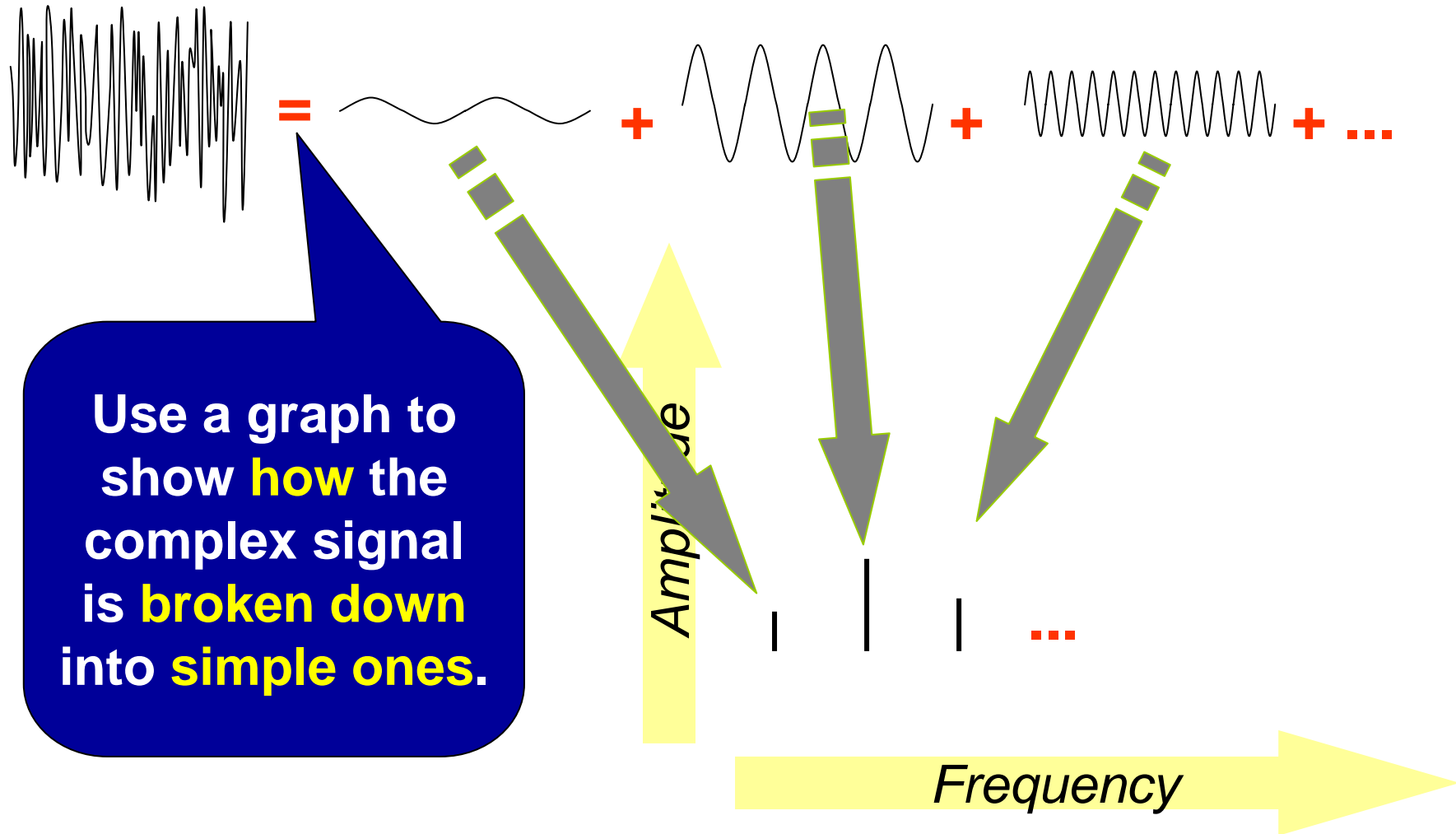

Time & Frequency Domain

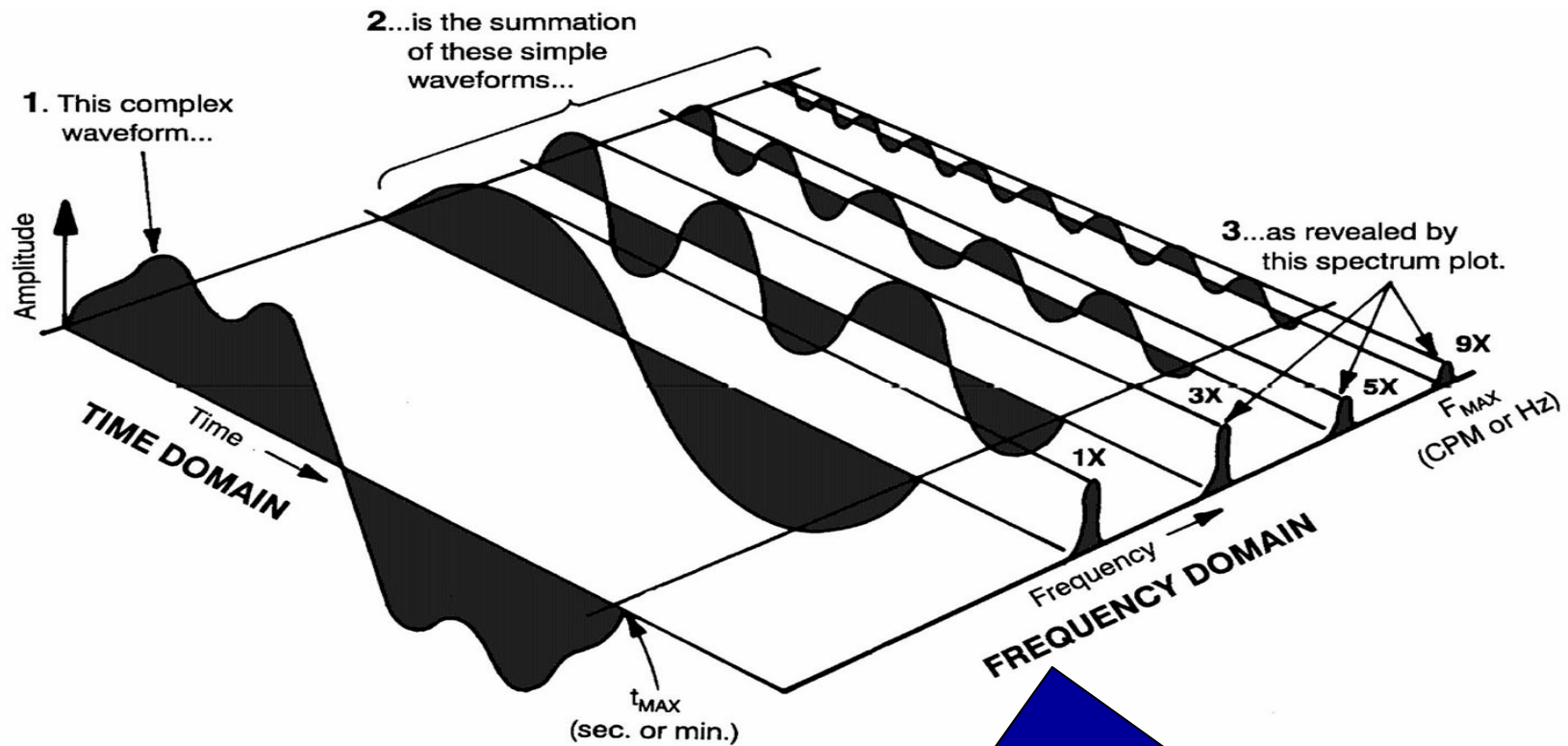

Time Domain waveform shown as many different frequencies and amplitudes

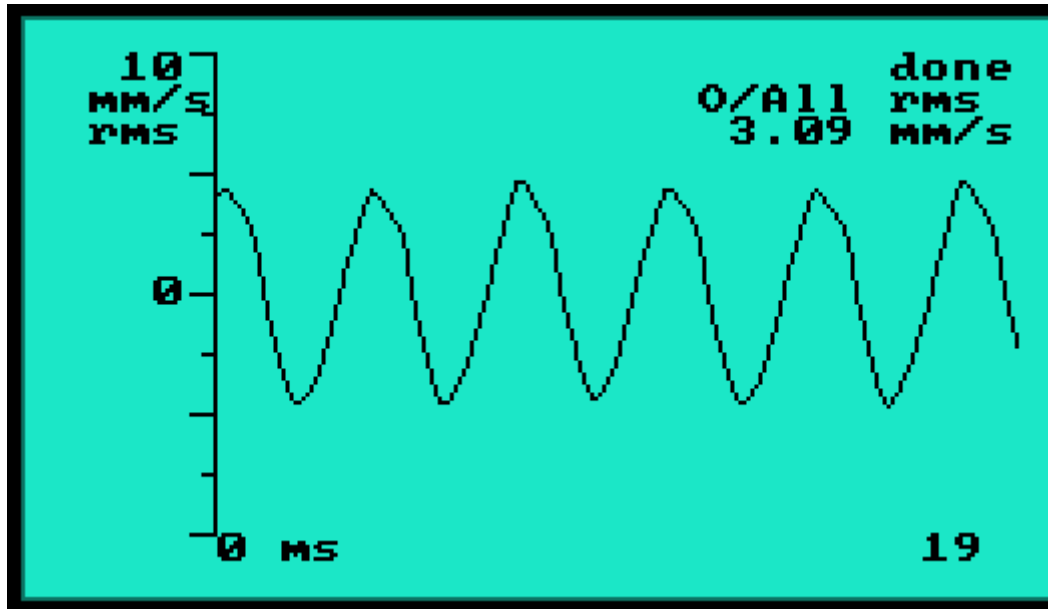

**Sinusoidal
time domain**

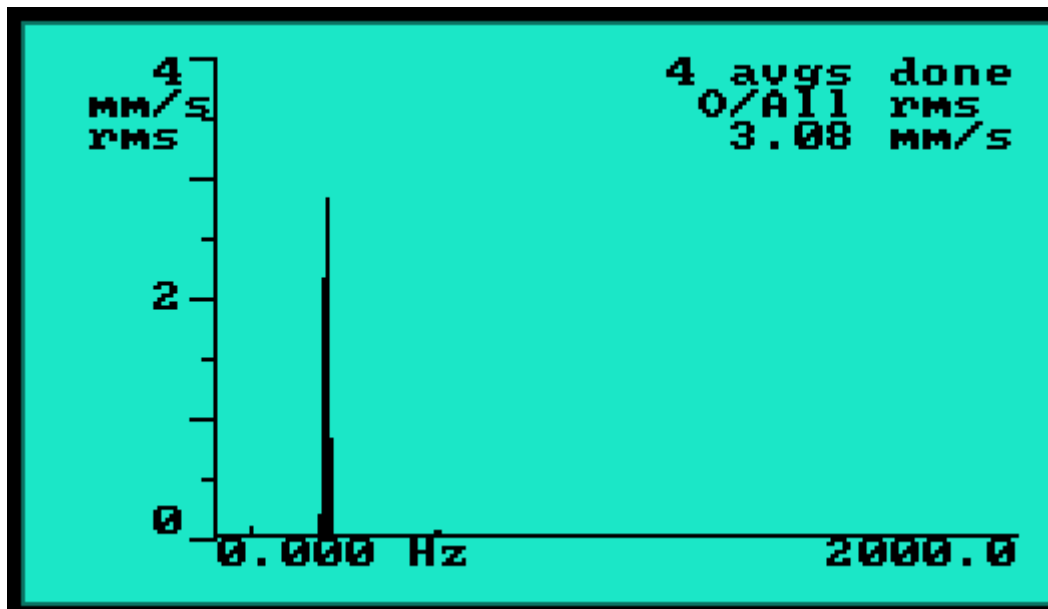

**Single peak in
frequency
domain.**

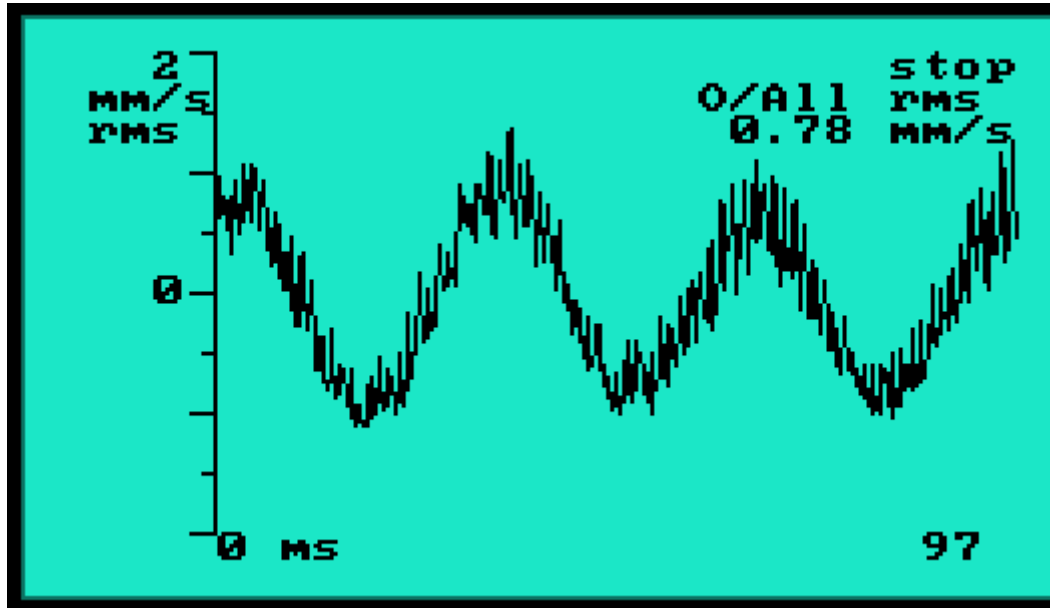

Noise in time domain

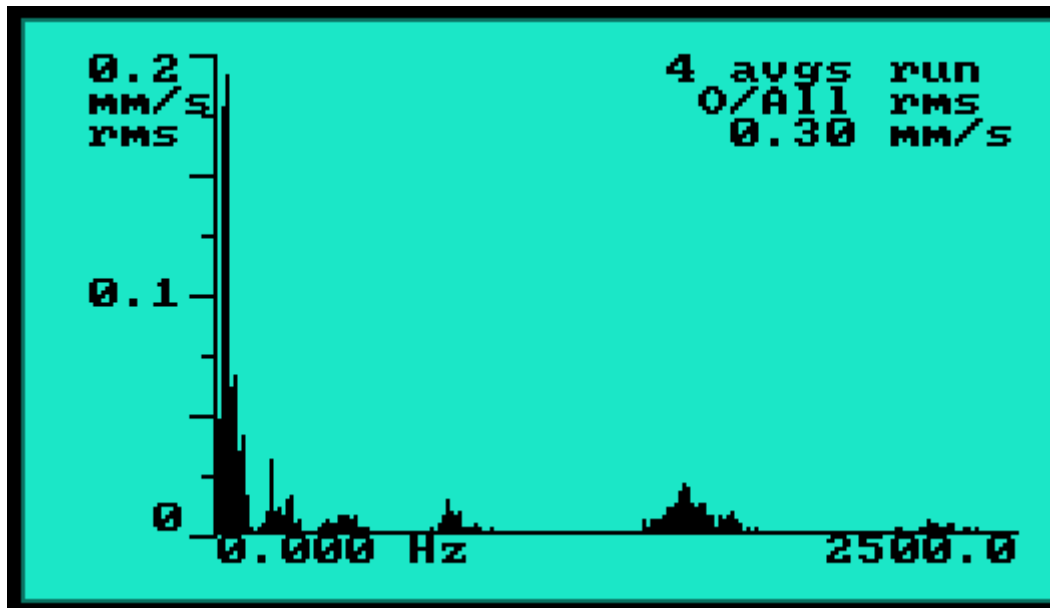

Noise in frequency domain

Review

- **Vibration measurement**
 - Point & Direction
- **Displacement, velocity, acceleration**
- **Time domain waveforms**
- **Complex vibration**
 - = sum of simple vibrations
- **Frequency domain**